

Recessed side lit LED panel suitable for exposed tee 15/24mm

- Schools
- Colleges
- Hospitals
- Offices
- Boardrooms



Features

- Aluminium base plate
- Die-Cast Aluminium bezel
- Epoxy powder coated RAL9016
- IP20
- Satin Diffuser 850° Glow wire test
- UGR<19

Options

- Integrated 3hr emergency -Standard (**M3**) – Self-Testing Emergency (**STE**)
- DALI (**DA**)
- Casambi Wireless Control (**BTC**)

Dimensions

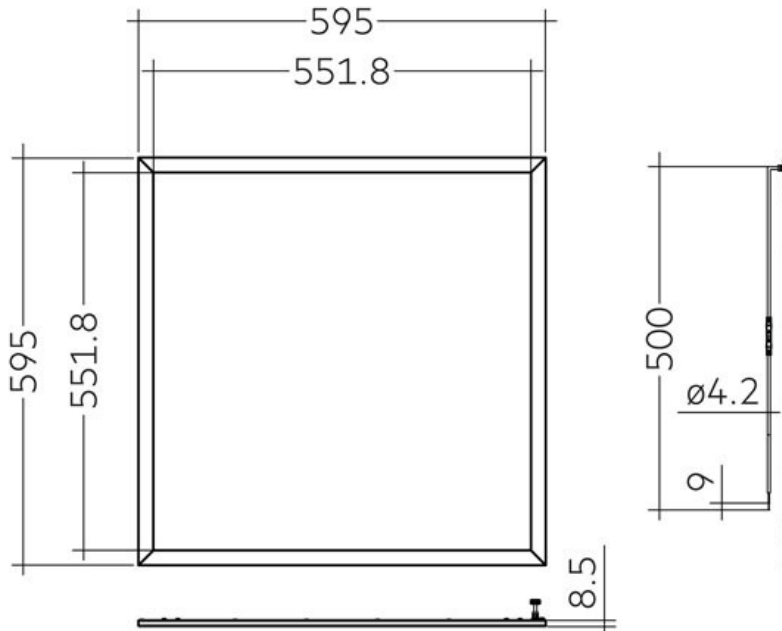

Product Code

DPV-23-4K-UGR-WH	Delta Advance 23w, 3,049lm, 600mA, 4K, 595mm x 595mm LED panel
DPV-31-4K-UGR-WH	Delta Advance 31w, 4,295lm, 800mA, 4K, 595mm x 595mm LED panel
DPV-35-4K-UGR-WH	Delta Advance 35w, 4,447lm, 900mA, 4K, 595mm x 595mm LED panel

** Suffix end of code (**M3**) for emergency facility or (**DA**) for DALI/Switch DIM or (**BTC**) for Casambi Wireless Control

** Suffix 4K to 3K for 3000 Kelvin